



VAPORMIST®

Electric-to-Steam Humidifier

- *Adaptable*
- *Reliable*
- *Easy to maintain*
- *Comprehensive control with Vapor-logic®*

Versatility for finished spaces



DriSteem® offers Space Distribution Units that match the Vapormist cabinet. See Page 13.

The Vapormist humidifier is a compact, cabinet-style unit compatible with all water types (tap, softened, deionized, reverse osmosis) and numerous dispersion options. Installation is a snap — just attach the frame to a supporting structure and connect electrical and water services.

Available matching Space Distribution Units disperse steam with no visible vapor trail, making Vapormist ideal for use in finished spaces.

COMPREHENSIVE CONTROL WITH VAPOR-LOGIC

Vapormist with Vapor-logic sets new standards for control in electric steam humidification:

Interoperability allows communication with building automation systems via Modbus or with optional BACnet or LonTalk protocols.

Safety presets initiate fill and drain cycles and keep the humidifier cool and safe if sensed conditions, though unlikely, could be hazardous.

Web-enabled control allows you to set up, view, and adjust humidifier functions via Ethernet, either directly or remotely through a network.



STATUS
ALARMS
DIAGNOSTICS
SETUP
HELP

System Status

SPACE RH	SET POINT	OUTPUT
33%	35%	12.3%

RUN MODE Auto

TANK STATUS Boiling

Alarms
0 active alarms
[View Alarms](#)

Messages
0 active messages
[View Messages](#)

Monday, December 03, 2012 10:40:18 AM Data stream is LIVE

View all humidifier settings below. Some settings can be changed here. Go to the Setup tab to change settings that cannot be changed from this page.

TANK STATUS:		
Run Mode	Auto	CHANGE
Space RH	33%	
RH set point	35%	CHANGE
Input signal	9.3 mA	
Steam output	12.3%	
Steam production	37.4 lbs/hr	
Duct HL switch	Closed	
Tank temperature	194°F	
Tank temp signal	1637 Ohms	
High water probe	Water	
Mid water probe	Water	
Low water probe	Water	
Fill valve	Closed	
Drain valve	Closed	
Airflow switch	Flow	
Interlock switch	Closed	
H2O until drain/flush	9120 lbs	
H2O until service	304000 lbs	
High probe signal	1	
Mid probe signal	1	
Low probe signal	1	

VERSATILE

- Uses tap, softened, or RO/DI water
- Capacity from 6 to 102 lbs/hr (2.7 to 46 kg/h), link up to 16 units for capacity up to 1632 lbs/hr (740 kg/h)
- Disperses steam through ductwork with dispersion tubes or panels, or directly into a room with a Space Distribution Unit (SDU) mounted remotely or on top of the Vapormist

FLEXIBLE

- Control to $\pm 3\%$ RH
- On-off or time-proportioned (TP) control for application control in most environments; solid-state relay (SSR) option for tight control
- Electronically monitored water level ensures safe and reliable operation

EASY TO MAINTAIN

- Removable cover allows easy access to evaporating chamber and electrical connections
- Softened water significantly reduces maintenance requirements
- End-of-season autodrain minimizes microbial growth
- User-adjustable water skimmer skims off floating minerals
- Controller-operated drain and flush removes precipitated minerals from evaporating chamber
- Constant thermal expansion and contraction of heating elements continuously sheds mineral buildup

DRISTEEM DISPERSION: PROVEN AND GUARANTEED

When it comes to absorption performance, competitors don't come close to DRI-STEEM's proven and guaranteed dispersion systems. Define your dispersion requirements and DriSteem will meet or exceed them. Guaranteed.

SAVE EVEN MORE ENERGY WITH OUR HIGH-EFFICIENCY TUBE OPTION

An option for new and existing Ultra-sorb® and Rapid-sorb® dispersion assemblies, High-Efficiency Tubes provide significant energy savings: Wasted energy is reduced by up to 85%. Airstream heat gain and condensate are also significantly lowered. See Pages 14-15 for more information.



Vapor-logic controller

KEYPAD/DISPLAY



WEB INTERFACE



Insert a USB flash drive into the Vapor-logic4 board's USB port to perform software updates, download data logs, and back up and restore data.

ACCURATE, RESPONSIVE CONTROL

The Vapor-logic controller provides accurate, responsive RH control. PID control tunes the system for maximum performance.

[Modbus](#), [BACnet](#), or [LonTalk](#) allow interoperability with multiple building automation systems. Modbus is standard, and BACnet or LonTalk are available options.

[Web interface](#) provides the capability to set up, view, and adjust humidifier functions via Ethernet, either directly or remotely through a network.

[Cycle counter](#) triggers a message when it's time to replace the contactor.

[USB port](#) allows easy firmware updates, and data backup and restore capability.

[Real-time clock](#) allows time-stamped alarm and message tracking, and accurate drain and flush scheduling.

[Auxiliary temperature sensor/transmitter](#) allows air temperature monitoring, such as in a duct, and enables temperature compensation to prevent window condensation.

[Programmable outputs](#) allow remote signaling and device activation.

[Multiple-humidifier control](#) allows staged control of up to 16 humidifiers with one controller.

[Controller data](#), such as RH, air temperature, water use, energy use, alarms, and messages, can be downloaded to a PC for viewing and analysis. RH, alarms, and messages can also be viewed on the keypad/display and Web interface.

[Enhanced diagnostics](#) include:

- [Test outputs](#) function using keypad/display or Web interface to verify component operation
- [Test humidifier](#) function using simulated demand to validate performance

mc_042710_1500-VM

VAPORMIST PRINCIPLE OF OPERATION

Tap/softened water Vapormist (shown with cover removed)

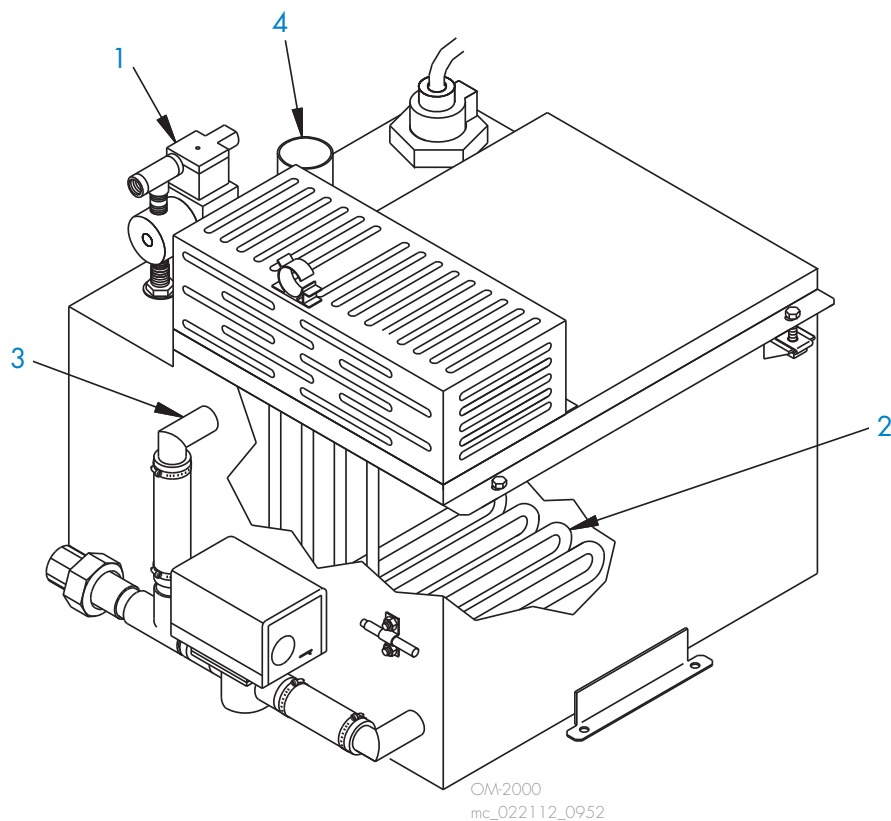

1. When the system is first activated, the fill valve opens and the evaporating chamber fills with water to the operating level.
2. On a call for humidity, the heating elements are energized, causing the water to boil. The fill valve opens and closes as needed to maintain the operating water level.
3. During refill in tap/softened water systems, a portion of the surface water is skimmed off, carrying away precipitated minerals.

Systems with the RO/DI water option (using deionized water or water that has been treated using reverse osmosis) do not require skimming.

4. Steam created in the evaporating chamber flows through steam hose, tubing, or piping to the dispersion assembly, where it is discharged into the airstream.

mc_022112_0953

KEYPAD/DISPLAY



VAPORMIST COMPONENTS

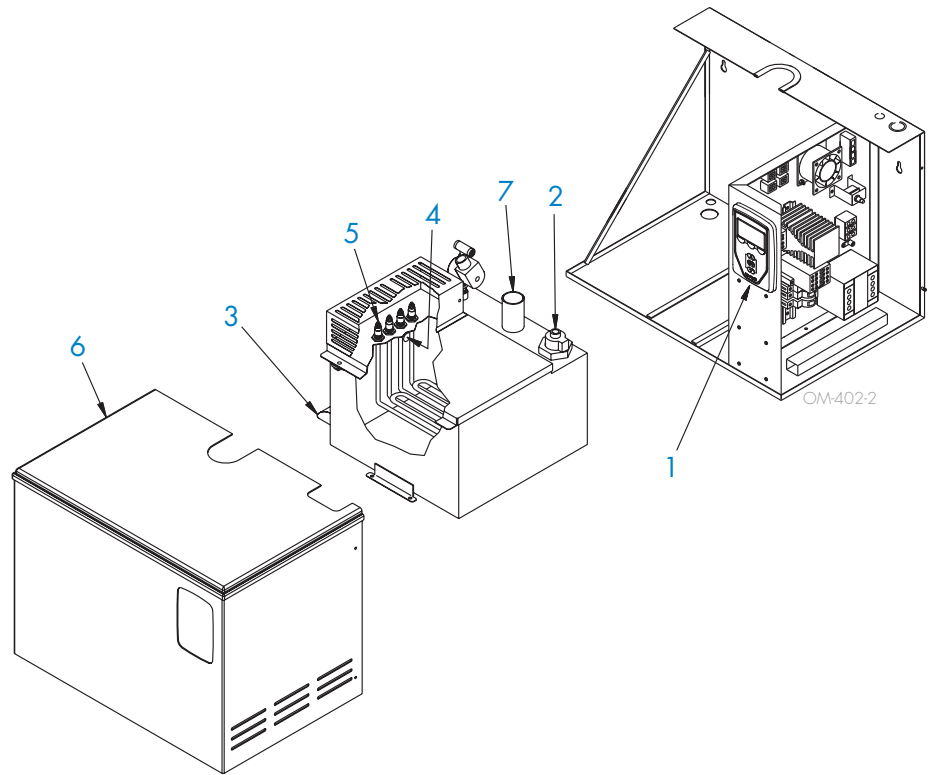

1. VAPOR-LOGIC CONTROLLER

Vapor-logic controls all humidifier functions and can connect to a building automation system via Modbus or optional BACnet or LonTalk. See Page 4 for more information.

2. WATER LEVEL CONTROL

Tap/softened water systems control water levels electronically using a three-rod probe, see figure at right.

Systems with the RO/DI water option control water levels using a float valve, see figure at right, and low-water cutoff switch.

3. DRAIN

Duration and frequency of draining are user adjustable. To avoid possible stagnant water and microbial growth, the humidifier automatically drains if there is no call for humidity after a user-defined time period (72-hour default).

4. WATER SKIMMER/OVERFLOW PORT

In tap/softened water systems, the water skimmer reduces surface minerals in the evaporating chamber. Skimming occurs each time the humidifier fills. The skim time duration is user-adjustable.

Systems with the RO/DI water option do not require skimming; the skimmer port functions as an overflow port.

5. HEATING ELEMENTS

Low-watt-density Incoloy-sheathed heating elements ensure operation for many seasons. Constant expansion and contraction of heating elements sheds mineral scale. In the unlikely event of heater failure, heating elements can be removed easily.

6. REMOVABLE COVER

A removable cover allows easy access to the evaporating chamber, electrical connections, and drain.

7. STEAM OUTLET

Steam generated in the humidifier rises through the steam outlet and travels to the dispersion assembly through vapor hose or piping.

8. TEMPERATURE SENSOR (NOT SHOWN)

Mounted on the evaporating chamber, this sensor enables:

- Over-temperature protection
- Freeze protection
- Preheating, allowing rapid response to a call for humidity

WATER LEVEL CONTROL FOR TAP/ SOFTENED WATER HUMIDIFIER

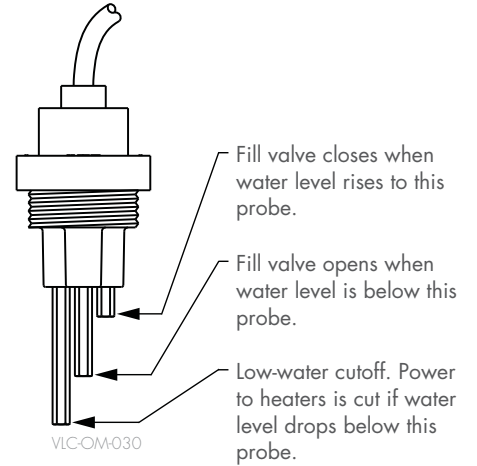

Humidifiers using tap or softened water control water levels electronically using a three-rod probe. The controller responds with the above actions when the water level reaches each rod.

mc_030910_1335

WATER LEVEL CONTROL FOR RO/DI WATER OPTION HUMIDIFIER

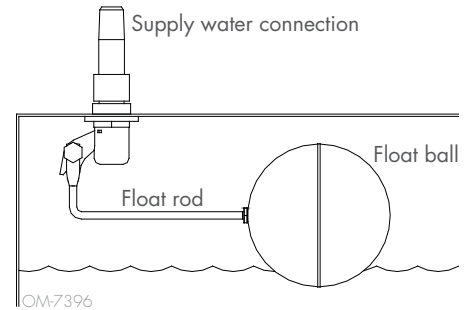

Humidifiers using RO/DI water control water levels using a float valve and low-water cutoff switch.

mc_052710_1644

Table 8-1:
Vapormist capacities, electrical specifications, and weights

VM model	Maximum steam capacity		Current draw (amps)											Weights ‡			
			Single-phase						Three-phase					Shipping		Operating	
kW	lbs/hr	kg/h	120V	208V*	240V*	277V	480V†	600V†	208V*	240V†	277V	480V†	600V†	lbs	kg	lbs	kg
2	6	2.7	16.7	9.6	8.3	7.2	4.2	3.3	—	—	—	—	—	80	36	95	43
4	12	5.4	33.3	19.2	16.7	14.4	8.3	6.7	16.7**	14.4**	12.5	7.2**	5.8**	80	36	95	43
6	18	8.2	—	28.8	25.0	21.7	12.5	10.0	25.0**	21.7**	18.8	10.8**	8.7**	88	40	122	55
8	24	10.9	—	38.5	33.3	28.9	16.7	13.3	33.3**	28.9**	25.0	14.4**	11.5**	88	40	122	55
10	30	13.6	—	—	41.7	36.1**	20.8	16.7	29.1**	25.3**	21.9	12.6**	10.1**	93	42	139	63
12	36	16.3	—	—	—	43.3	25.0	20.0	33.3	28.9	25.0	14.4	11.5	93	42	139	63
14	42	19.1	—	—	—	—	29.2	23.3	38.9	33.7	29.2	16.8	13.5	93	42	139	63
16	48	21.8	—	—	—	—	33.3	26.7	44.4	38.5	33.3	19.2	15.4	93	42	139	63
21	63	28.6	—	—	—	—	43.8	35.0	—	—	43.8	25.3	20.2	95	43	152	69
25	75	34.0	—	—	—	—	—	41.7	—	—	—	30.1	24.1	95	43	152	69
30	90	40.9	—	—	—	—	—	—	—	—	—	36.1	28.9	101	46	156	71
34	102	46.3	—	—	—	—	—	—	—	—	—	40.9	32.7	101	46	156	71

* On 208V/240V/single-phase/three-wire and on 208V/three-phase/four-wire supplies, the neutral line provides a separate 120V circuit for the SDU fan unit.

** For wire sizing, the highest leg draw is shown due to current imbalance.

† Add the following to Vapormist weights if using an SDU option (these weights are for additional control components housed within the Vapormist cabinet):

– SDU-I: 12 lbs (5.5 kg) (SDU-I shipping weight is 68 lbs [31 kg])

– SDU-E: 9 lbs (4 kg) (SDU-E shipping weight is 61 lbs [28 kg])

‡ Add the following if using the SSR option:

– For single-phase or three-phase models drawing less than 21.7 amps, add 2 lbs (1 kg)

– For three-phase models drawing more than 21.7 amps, add 4 lbs (2 kg)

All Vapormist models operate at 50/60 Hz.

mc_042610_0900

VAPORMIST CLEARANCE RECOMMENDATIONS

Maintain these clearances for service and maintenance.

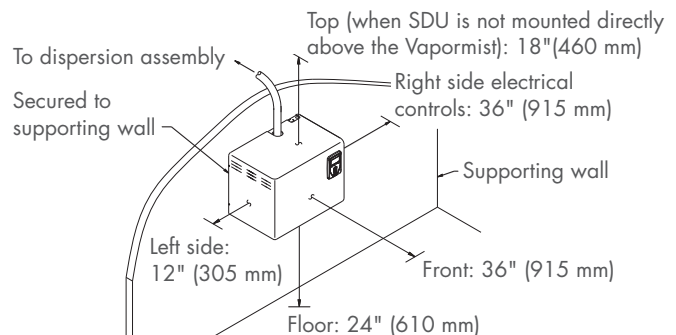

DC-1201
mc_042710_1326-VM

VAPORMIST DIMENSIONS

Top view

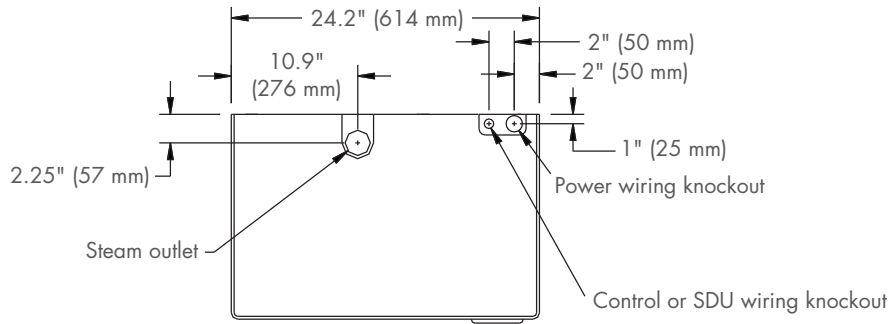

Left side view

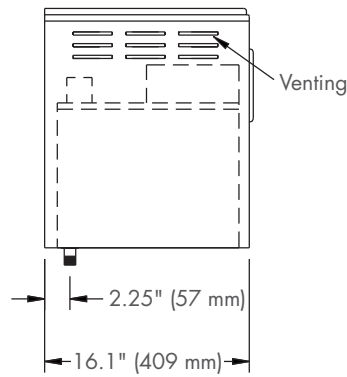

Front view

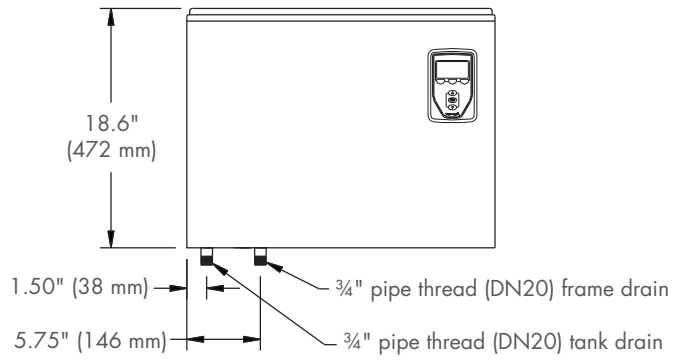

Bottom view

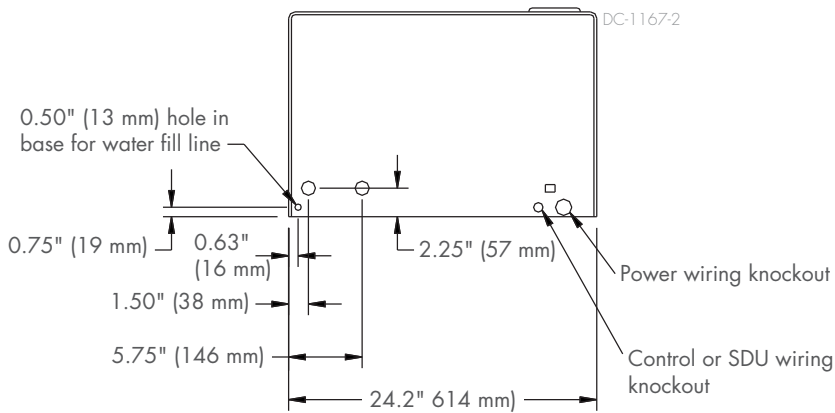

mc_042710_1325-VM

Vapormist piping: Tap/softened water

VAPORMIST (TAP/SOFTENED WATER) FIELD PIPING OVERVIEW

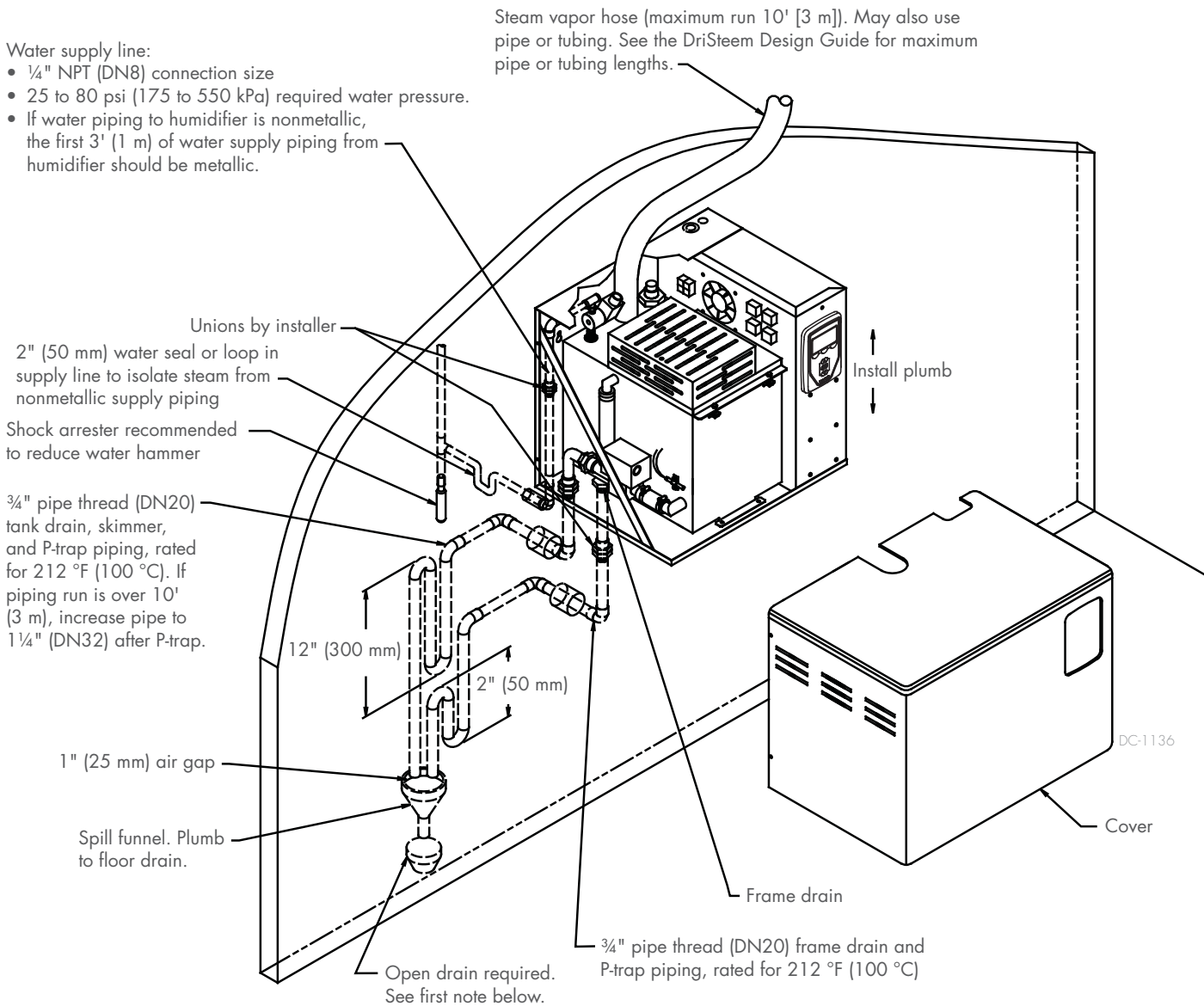

Notes:

- Locate air gap only in spaces with adequate temperature and air movement to absorb flash steam; otherwise, condensation may form on nearby surfaces. Refer to governing codes for drain pipe size and maximum discharge water temperature.
- Offset humidifier from spill funnel or floor drain to prevent flash steam from rising into cabinet.
- Dashed lines indicate provided by installer.
- Water supply inlet is more than 1" (25 mm) above skim/overflow port, eliminating the possibility of backflow or siphoning from tank. No additional backflow prevention is required; however, governing codes prevail.
- Install a union in water supply and drain lines as shown to allow tank removal.
- Damage caused by chloride corrosion is not covered by your DriSteem warranty.

mc_042710_1327-VM

VAPORMIST (RO/DI WATER) FIELD PIPING OVERVIEW

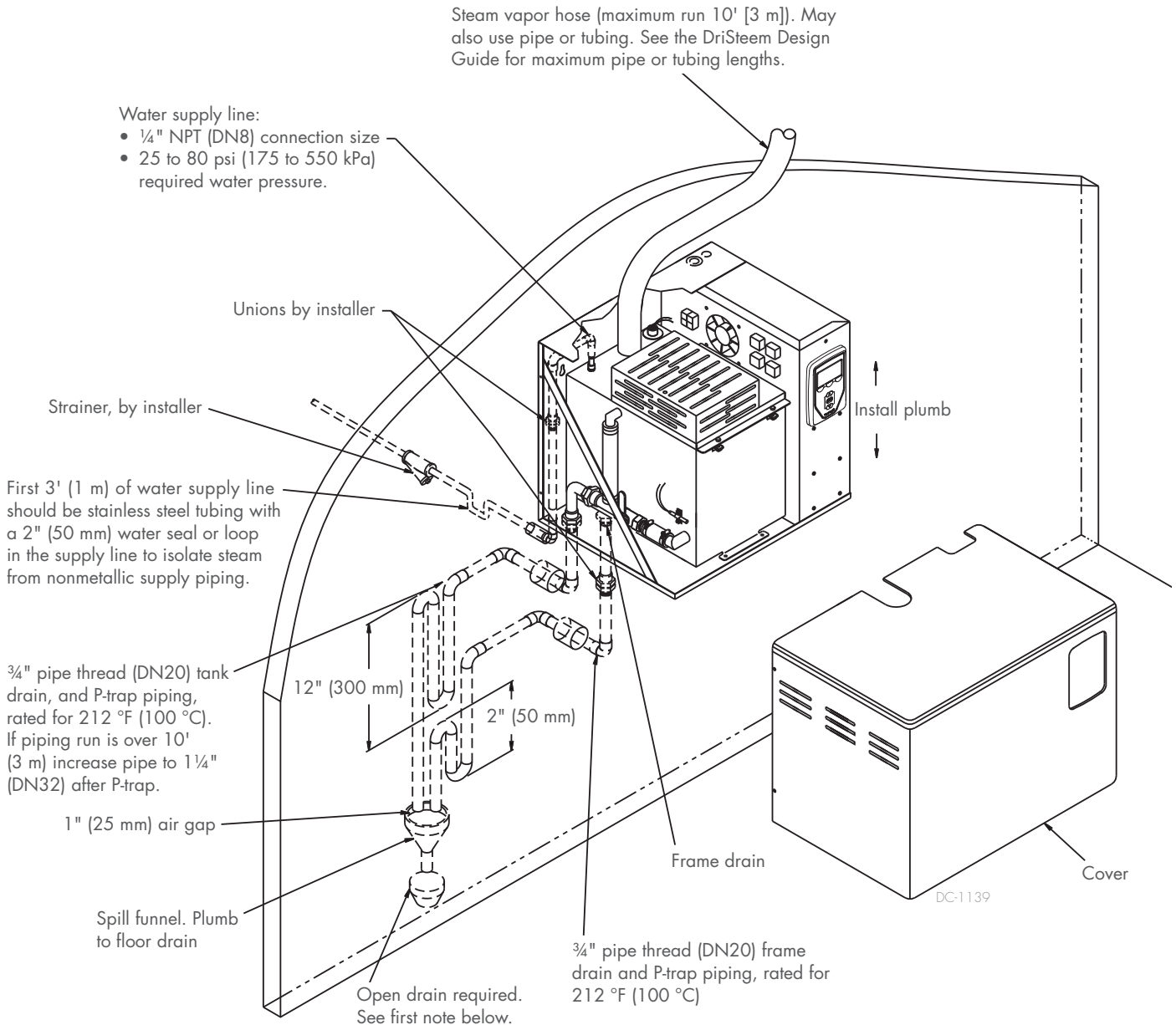

Notes:

- Locate air gap only in spaces with adequate temperature and air movement to absorb flash steam; otherwise, condensation may form on nearby surfaces. Refer to governing codes for drain pipe size and maximum discharge water temperature.
- Offset humidifier from spill funnel or floor drain to prevent flash steam from rising into the cabinet.
- Dashed lines indicate provided by installer.
- The water supply inlet is more than 1" (25 mm) above the overflow port, eliminating the possibility of backflow or siphoning from the tank. No additional backflow prevention is required; however, governing codes prevail.
- Install a union in the water supply and drain lines as shown to allow tank removal.
- Damage caused by chloride corrosion is not covered by your DriSteem warranty.

mc_042710_1328-VM

Vapormist steam dispersion options



Ultra-sorb Models LV

ULTRA-SORB MODELS LV AND LH

Most versatile

- Guaranteed, short non-wetting distances — install within inches of downstream devices
- Reduce wasted energy up to 85% and increase capacity with optional High-Efficiency Dispersion Tubes
- Lowest installation cost — factory assembly for easy installation

Capacity: Up to 1850 lbs/hr (840 kg/h) per panel



Ultra-sorb Models LH

HIGH-EFFICIENCY DISPERSION TUBES OPTION

For new and existing Ultra-sorb, Rapid-sorb, single dispersion tube

- Highest efficiency
- Increases tube capacity up to 6 lbs/hr (2.7 kg/h)
- Up to 85% reduction in wasted energy, airstream heat gain, and condensate production
- Plenum approved for in-duct installation



Ultra-sorb Model LV
with High-Efficiency Tubes

Rapid-sorb
with High-Efficiency Tubes



RAPID-SORB® DISPERSION TUBE SYSTEM

Multiple tubes, short non-wetting distance

- Short non-wetting distance, compared to single dispersion tube
- Horizontal or vertical airflows
- Install Rapid-sorb header inside or outside duct
- Available with High-Efficiency Dispersion Tubes

Capacity: Up to 2100 lbs/hr (955 kg/h) per system



Rapid-sorb dispersion tube system

SINGLE DISPERSION TUBE

Installation flexibility

- Low-capacity dispersion for horizontal or vertical airflows.
- Available as a High-Efficiency Dispersion Tube

Capacity: Up to 97 lbs/hr (38 kg/h)



Single dispersion tube

SPACE DISTRIBUTION UNITS

Quiet, fan-based steam dispersion

- SDUs mount on top of Vapormist humidifiers or remotely
- Designed for finished spaces

Capacity: Up to 102 lbs/hr (46.3 kg/h)



SDU mounted on Vapormist humidifier

DriSteem Corporation

A subsidiary of Research Products Corporation
An ISO 9001:2000 certified company

U.S. Headquarters:
14949 Technology Drive
Eden Prairie, MN 55344
800-328-4447 or 952-949-2415
952-229-3200 (fax)

European office:
Marc Briers
Grote Hellekensstraat 54 b
B-3520 Zonhoven
Belgium
+3211823595 (voice)
+3211817948 (fax)
E-mail: marc.briers@dristeem.com

Continuous product improvement is a policy of DriSteem Corporation; therefore, product features and specifications are subject to change without notice.

DriSteem, Rapid-sorb, Ultra-sorb, Vapor-logic, and Vapormist are registered trademarks of DriSteem Corporation and are filed for trademark registration in Canada and the European community.

Product and corporate names used in this document may be trademarks or registered trademarks. They are used for explanation only without intent to infringe.

© 2013 DriSteem Corporation



Form No. Vapormist-Catalog-0113

EXPECT QUALITY FROM THE INDUSTRY LEADER

For more than 45 years, DriSteem has been leading the industry with creative and reliable humidification solutions. Our focus on quality is evident in the construction of the Vapormist humidifier. DriSteem leads the industry with a Two-year Limited Warranty and optional extended warranty.

For more information
www.dristeem.com
sales@dristeem.com

For the most recent product information visit our website:
www.dristeem.com

Your DriSteem Representative is: